

TX□E Type

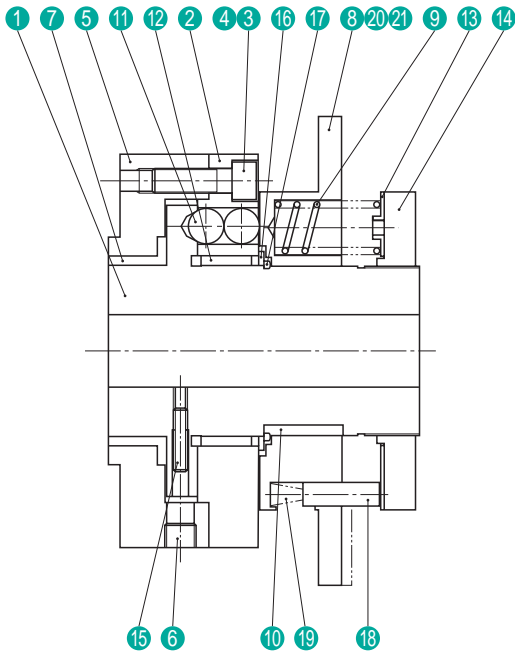

TX30E



● ADOPTION EXAMPLES



PAPER MAKING MACHINE UNWINDER

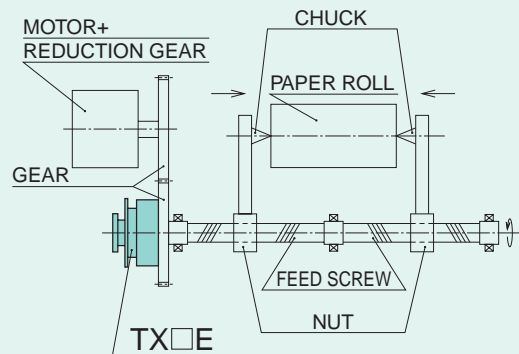

● NAMES OF PARTS

1	Hub boss
2	Housing
3	Hexagon socket head bolt
4	Spring pin
5	Flange
6	Hexagon socket head plug
7	Metal
8	Action ring
9	Spring
10	Key
11	Steel ball
12	Bearing
13	Washer
14	Adjusting ring
15	Hexagon socket head setscrew
16	Ring
17	WR type stopper ring
18	Pin
19	Spring
20	Model name plate
21	Name plate

*Dimensions and specifications might be changed for improvement without notice.