

TY□D Type

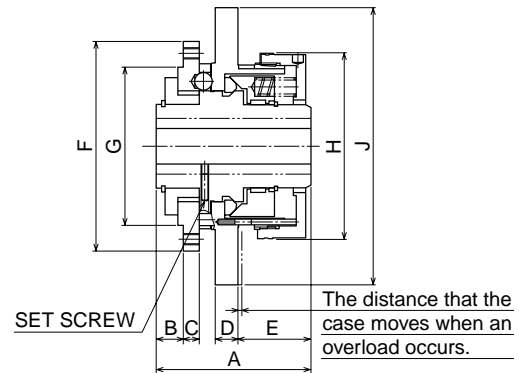
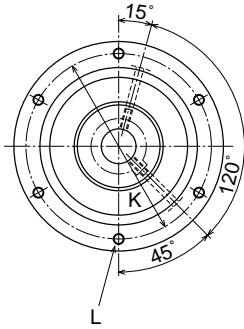

● DIMENSION TABLE

| MODEL | A | B | C | D | E | φF | φG | φH | φJ | MOUNTING BOLT | |
|-----------------|-----|----|----|----|------|-----|-------------------------------------|-----|-----|---------------|-------------|
| | | | | | | | | | | K PCD | L BOLT SIZE |
| TY30D-L · H · G | 85 | 15 | 9 | 12 | 40.4 | 113 | 85 ⁺⁰ _{-0.035} | 102 | 150 | 100 | 6-M6 |
| TY40D-L · H · G | 95 | 18 | 10 | 12 | 42.3 | 134 | 105 ⁺⁰ _{-0.035} | 122 | 175 | 120 | 6-M8 |
| TY50D-L · H · G | 115 | 24 | 10 | 16 | 49.9 | 168 | 130 ⁺⁰ _{-0.040} | 147 | 210 | 150 | 6-M10 |

● SPECIFICATIONS

| MODEL | TORQUE RANGE N·m | SPRING COLOR × QTY | MAX SPEED min ⁻¹ | INERTIA MOMENT kg·m ² | WEIGHT kg | MAX HOLE DIA φ mm | STANDARD HOLE DIA φ mm | PREPARED HOLE DIA φ mm | SET SCREW | RELEASE DISTANCE mm |
|---------|---------------------|-----------------------|-----------------------------------|--|--------------|-------------------------|------------------------------|------------------------------|--------------|---------------------------|
| TY30D-L | 26 ~ 94 | WHITE × 16 | 400 | 7.6 × 10 ⁻³ | 4.0 | 30 | 30H × 8Js9 | 19 | 2-M4 | 2.4 |
| TY30D-H | 43 ~ 170 | R E D × 8 | | | | | | | | |
| TY30D-G | 89 ~ 200 | R E D × 16 | | | | | | | | |
| TY40D-L | 56 ~ 180 | WHITE × 16 | 310 | 17.7 × 10 ⁻³ | 7.0 | 40 | 40H7 × 12Js9 | 24 | 2-M5 | 2.8 |
| TY40D-H | 67 ~ 400 | R E D × 8 | | | | | | | | |
| TY40D-G | 160 ~ 400 | R E D × 16 | | | | | | | | |
| TY50D-L | 50 ~ 290 | WHITE × 16 | 240 | 46.9 × 10 ⁻³ | 14.0 | 50 | 50H7 × 14Js9 | 34 | 2-M6 | 3.6 |
| TY50D-H | 100 ~ 520 | R E D × 8 | | | | | | | | |
| TY50D-G | 180 ~ 800 | R E D × 16 | | | | | | | | |

- The operating torque varies according to the number of springs used.
Up to three springs can be used.

*Dimensions and specifications are subject to change without prior notice.